

REV.	ECN NO	LOCATIONS	DESCRIPTION	DATE	REVISER	APPD

NOTE:

1.ELECTRICAL CHARACTERISTICS;

1.1 CONTACT RESISTANCE: 40mΩ Max FOR INITIAL. 50mΩ CHANGE AFTER TEST. MEASURE AT 20mV, 100mA.

1.2 CONTACT CURRENT RATING: 5A FOR VBUS PIN; 1.25A FOR VCONN PIN.

1.3 DIELECTRIC WITHSTANDING VOLTAGE: 100V AC R.M.S.

1.4 INSULATION RESISTANCE 100MΩ Min

1.5 OPERATING TEMPERATURE: -40°C~85°C

2.MECHANICAL CHARACTERISTICS:

2.1 MATING FORCE: 5~20N

2.2 UNMATED FORCE: 8~20N

2.3 DURABILITY: 10,000 CYCLES

5	Shell	1	SUS	T=0.15mm	60u"min. Nickel Plated
4	EMI Spring	2	SUS	--	No Plated
3	GND LATCH	1	SUS	T=0.35mm	Solder area: matte Tin Plated
2	Contact	24	COPPER ALLOY	T=0.15mm	Contact area: 30u"(PD/Ni+)Gold Flash Solder area: 80u"min. matte Tin Plated over Nickel
1	Housing	3	THERMOPLASTIC	UL 94-V0	Black
No.	Name	Q'ty	Material	Remarks & Thickness	Finish

PRAT NO: U31C888-01SK	MATERIAL:	HC HSI-CHIN ELECTRONICS CO.,LTD	
MODEL NO:	FINSH:		
UNIT: mm	SAZE: A4	COLOR:	PART NAME:
TOLERANCE UNSPECIFIED	DR: 劉群 '18/08/01	USB TYPE-C PLUG	
.X ±0.30	CHK: 楊育成 '18/08/01	DWG NO: S/A-726	REV. A2
.XX ±0.20	APP: Kent '18/08/01	SCALE: 1:1	SHEET: 1 of 2
.XXX ±0.10			
ANG ±1			

ROHS Compliant

1 2 3 4 5 6 7 8

REV.	ECN NO	LOCATIONS	DESCRIPTION	DATE	REVISER	APPD

TOP VIEW

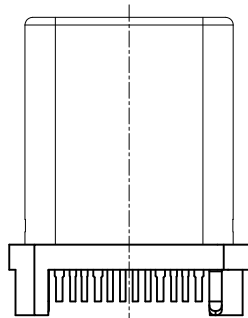

Connector
BOTTOM VIEW

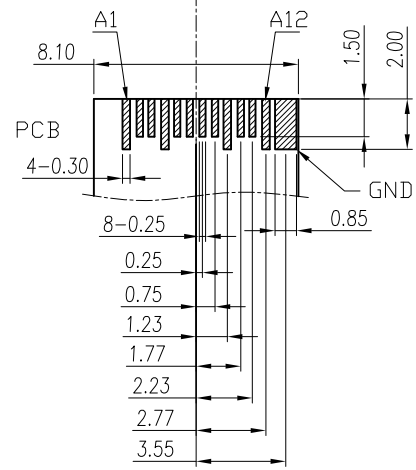
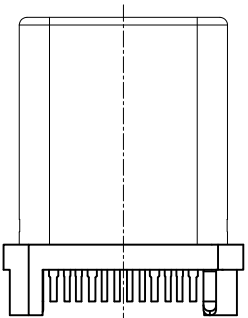

RECOMMEND PCB LAYOUT
TOP VIEW

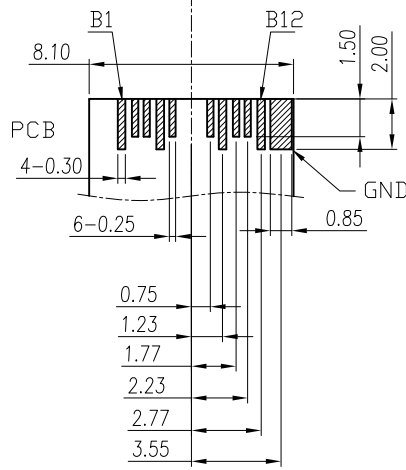

RECOMMEND PCB LAYOUT
BOTTOM VIEW

Pin Assignments

Pin No	Signal Name	Signal Name	Pin No
A1	GND	GND	B12
A2	TX1+	RX1+	B11
A3	TX1-	RX1-	B10
A4	Vbus	Vbus	B9
A5	CC	SBU2	B8
A6	D+		B7
A7	D-		B6
A8	SBU1	Vconn	B5
A9	Vbus	Vbus	B4
A10	RX2-	TX2-	B3
A11	RX2+	TX2+	B2
A12	GND	GND	B1

ROHS Compliant

PRAT NO:	MATERIAL:	
MODEL NO:	FINSH:	
UNIT: mm	SAZE: A4	COLOR:
TOLERANCE UNSPECIFIED	DR: 劉群 '18/08/01	PART NAME:
.X ±0.30	CHK:楊育成 '18/08/01	USB3.1-C TYPE(M)180°夾板式
.XX ±0.20	APP: Kent '18/08/01	DWG NO: S/A-726
.XXX ±0.10		SCALE: 1:1
ANG ±1°		SHEET: 2 of 2
		REV. A2

1 2 3 4 5 6 7 8