

REV.	ECN NO	LOCATIONS	DESCRIPTION	DATE	REVISER	APPD

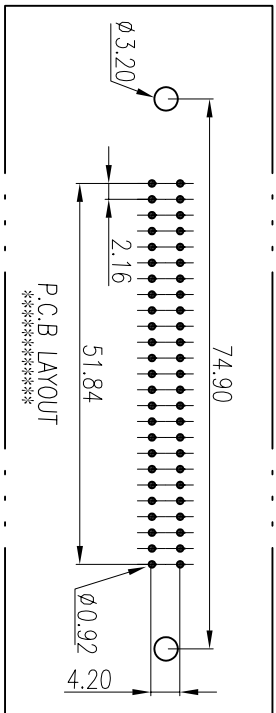
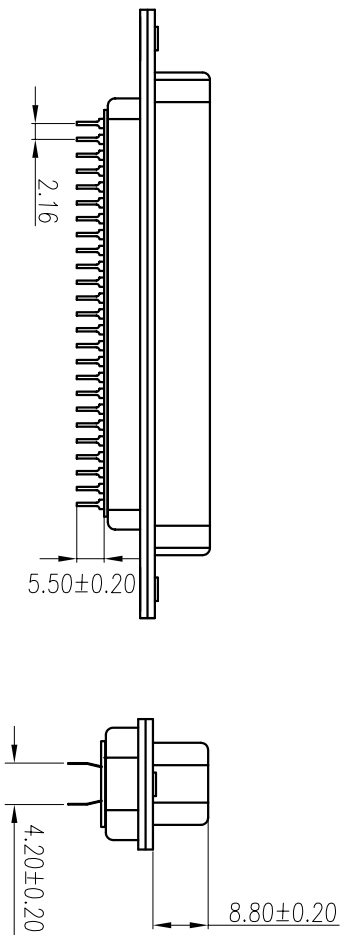
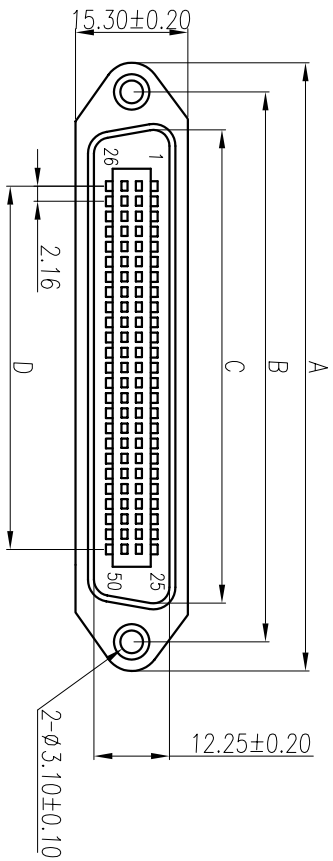

- Note:
- 1.Material:
- 1.1 Insulator: P.B.T UL 94-V0 rated.
 - 1.2 Contact: Phosphor bronze,t=0.25mm.
 - 1.3 Front shell: Cold rolled steel,t=0.45mm,0.50mm,0.60mm.
 - 1.4 Back shell: Cold rolled steel,t=0.40mm.

2.Specification:

- 2.1 Current rating: 1 A Max.
- 2.2 Dielectric withstanding voltage: 500 V(ac) for 1 minute.
- 2.3 Contact resistance: 30 mΩ Max.
- 2.4 Insulation resistance: 1000 MΩ Min at DC 500V.
- 2.5 Temperature range: -55°C~+105°C

3.Finishes:

- 3.1 contacts:Gold flashed 1u",3u",5u",10u",15u",30u".
- 3.2 Shell: Nickel,tin plated

No.	Name	Q'ty	Material	Remarks & Thickness	Finish
4	Back-shell	1	Cold Rolled Steel	T=0.40mm	Tin Plated
3	Front-shell	1	Cold Rolled Steel	T=0.45mm,0.50mm,0.60mm	Nickel Plated
2	Contact	14-50	Phosphor Bronze	T=0.25mm	Gold Flashed
1	Housing	1	P.B.T	UL 94-V0	Black/White/Blue

PART NO	A±0.20	B±0.20	C±0.20	D±0.20
CN-14P	43.90	36.00	25.50	12.96
CN-24P	54.70	46.80	36.30	23.76
CN-36P	67.70	59.70	49.30	36.72
CN-50P	82.80	74.90	64.40	51.84

PART NO:		MATERIAL:	
MODEL NO:		FINSH:	
UNIT: mm	SIZE: A4	COLOR:	
TOLERANCE UNSPECIFIED			
x	±0.3	DR: 段林麗 06/03/10	
.xx	±0.20	CHK: Song 06/03/10	
.xxx	±0.100	APP: Kent 06/03/10	
ANG.	±1°	SCALE: 1:1	
PART NAME:		DWG NO:	
CENTRONC P.C.B 180° STRAIGHT(M)		REV: A0	
SHEET: 1 of 1		REV: A0	

HSI-CHIN ELECTRONICS CO.,LTD