

REV.	ECN NO	LOCATIONS	DESCRIPTION	DATE	REVISER	APPD

- Note:
1. Material:
- 1.1 Insulator: P.B.T UL 94-V0 rated.
 - 1.2 Contact: Brass, T=0.20mm.
 - 1.3 Front shell: Cold rolled steel, t=0.45mm, 0.50mm, 0.60mm
 - 1.4 Back shell: Cold rolled steel, t=0.40mm.

2. Specification:
- 2.1 Current rating: 1 A Max.
 - 2.2 Dielectric withstanding voltage: 500 V(ac) for 1 minute.
 - 2.3 Contact resistance: 30 mΩ Max.
 - 2.4 Insulation resistance: 1000 MΩ Min at DC 500V.
 - 2.5 Temperature range: -55°C~+105°C

3. Finishes:
- 3.1 Contacts: Gold flashed 1u", 3u", 5u", 10U", 15u", 30u".
 - 3.2 Shell: Nickel, tin or gold plated

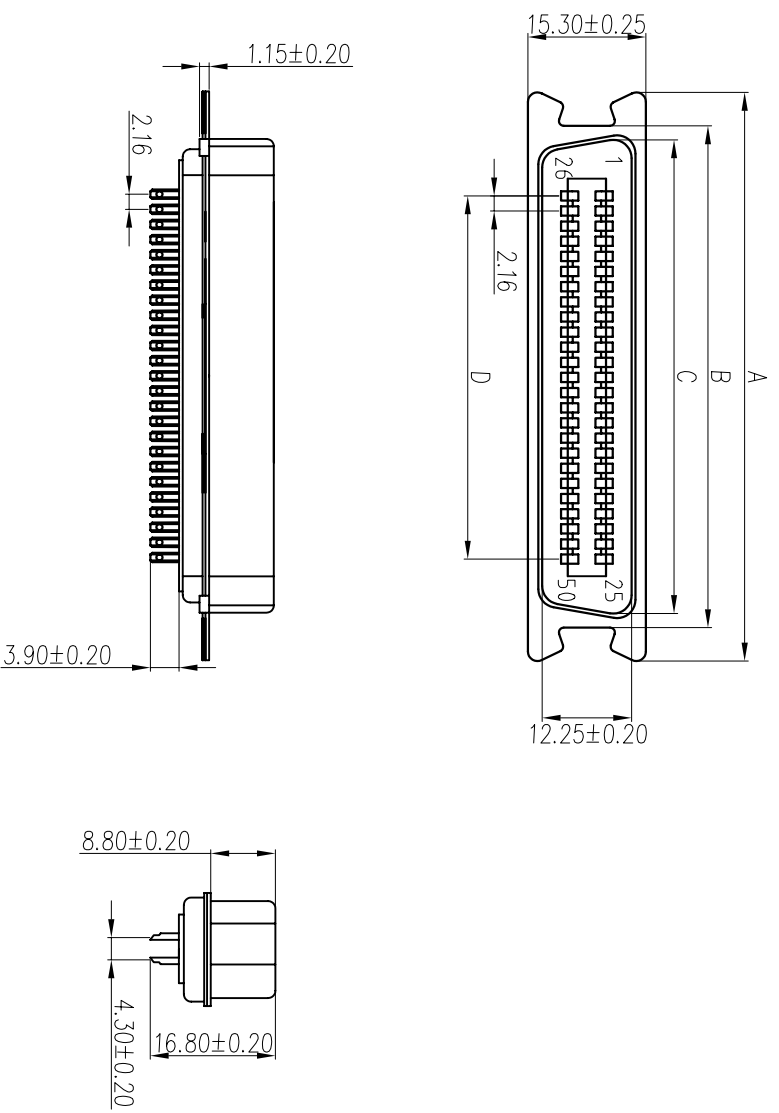

PART NO	A±0.20	B±0.20	C±0.20	D±0.20
CN-14P	38.80	30.20	25.60	12.96
CN-24P	49.30	40.20	36.47	23.76
CN-36P	62.00	53.50	49.35	36.72
CN-50P	77.40	68.30	64.47	51.84

4	Back-shell	1	Cold Rolled Steel	T=0.40mm	Tin Plated
3	Front-shell	1	Cold Rolled Steel	T=0.45mm, 0.50mm, 0.60mm	Nickel Plated
2	Contact	14~50	Brass	T=0.20mm	Gold Flashed
1	Housing	1	P.B.T	UL 94-V0	Black/Blue/White

PART NO:	MATERIAL:	PART NAME:	
MODEL NO:	FINISH:	CENTRONIC SOLDER傳統	
UNIT: mm	COLOR:	DWG NO:	REV: A0
SIZE: A4	DR: 段林麗	SCALE: 1:1	SHEET: 1 of 1
TOLERANCE UNSPECIFIED	CHK: Song	APP: Kent	
x ±0.3			
.xx ±0.20			
.xxx ±0.100			
AVG. ±T			