

REV.	ECN NO	LOCATIONS	DESCRIPTION	DATE	REVISER	APPD

Note:

1. Material:

- 1.1 Insulator: P.B.T UL 94-V0 rated.
- 1.2 Contact: Brass,t=0.25mm.
- 1.3 Front shell: Cold rolled steel,t=0.45mm,0.50mm,0.60mm
- 1.4 Back shell: Cold rolled steel,t=0.40mm.

2. Specification:

- 2.1 Current rating: 1 A Max.
- 2.2 Dielectric withstanding voltage: 500 V(ac) for 1 minute.
- 2.3 Contact resistance: 30 mΩ Max.
- 2.4 Insulation resistance: 1000 MΩ Min at DC 500V.
- 2.5 Total mating force: 4.0 Kgf Max.
- 2.6 Total unmating force: 1.0 Kgf Min.
- 2.7 Temperature range: -55°C~+105°C

3. Finishes:

- 3.1 contacts: Gold flashed 1u", 3u", 5u", 10u", 15u", 30u".
- 3.2 Shell: Nickel, tin or gold plated

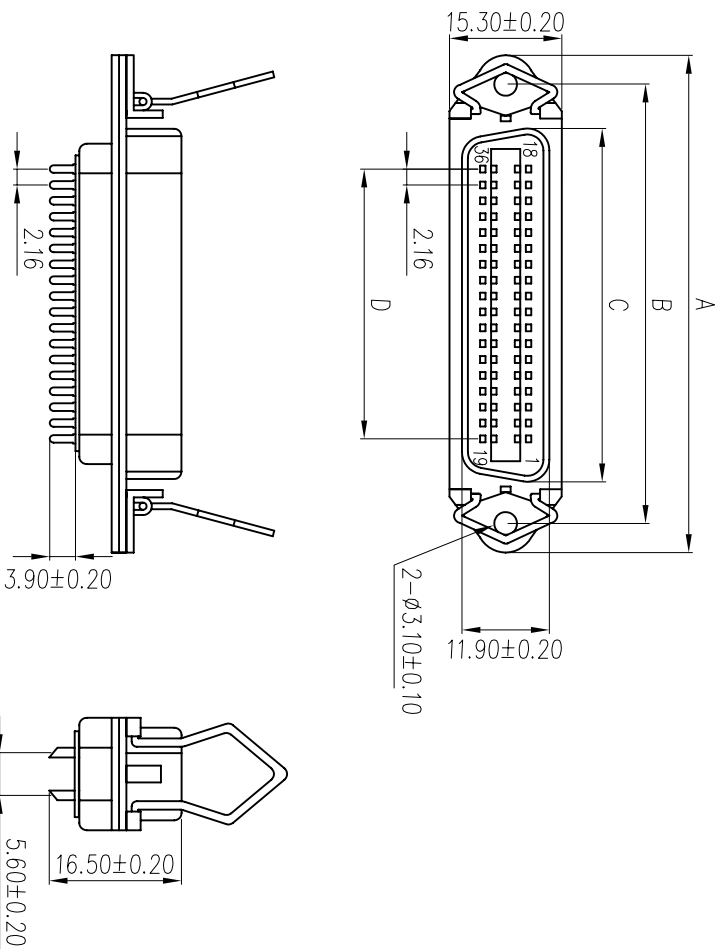

7	Trangle	2	Cold Rolled Steel	T=0.60mm	Nickel Plated
5	Spring	2	Stainless	∅0.9	Nickel Plated
4	Back-shell	1	Cold Rolled Steel	T=0.40mm	Tin Plated
3	Front-shell	1	Cold Rolled Steel	T=0.45mm, 0.50mm, 0.60mm	Nickel Plated
2	Contact	36	Brass	T=0.25mm	Gold Flashed
1	Housing	1	P.B.T	UL 94-V0	Black/White/Blue
No.	Name	Q'ty	Material	Remarks & Thickness	Finish

PART NO	A±0.20	B±0.20	C±0.20	D±0.20
CN-14S	43.90	35.99	25.20	12.96
CN-24S	54.71	46.79	36.00	23.76
CN-36S	67.69	59.74	48.90	36.72
CN-50S	82.78	74.85	64.00	51.84

PART NO:		MATERIAL:	
MODEL NO:		FINISH:	
UNIT: mm	SIZE:A4	COLOR:	
TOLERANCE UNSPECIFIED DR: 段林麗 '06/03/03			
X ±0.3	CHK: Song '06/03/03	DWG NO:	
.xx ±0.20	APP: Kent '06/03/03	SCALE: 1:1	SHEET: 1 of 1
.xxx ±0.100			
ANG. ±1			
PRT NAME:		REV: A0	
CENTRONIC SOLDER(F) 鍍三角片			

HSI-CHIN ELECTRONICS CO.,LTD

CENTRONIC SOLDER(F) 鍍三角片