

REV.	ECN NO	LOCATIONS	DESCRIPTION	DATE	REVISER	APPD

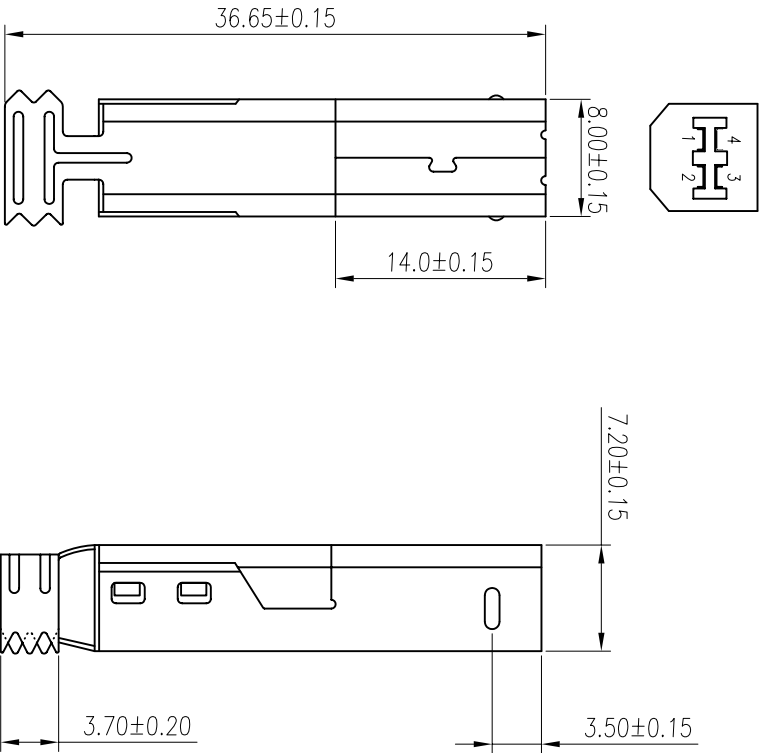
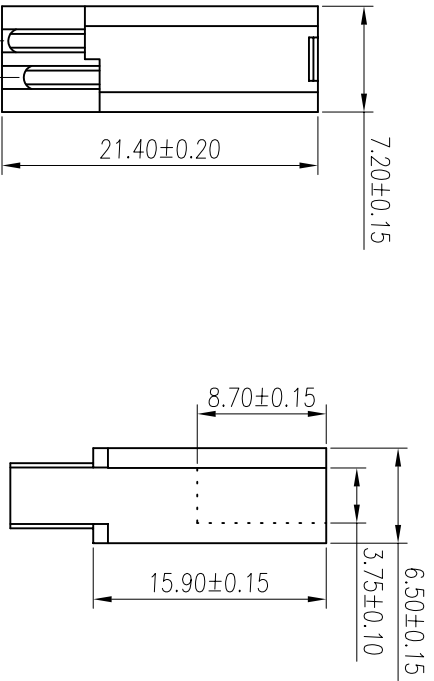

Note:

1.Material:

- 1.1 Insulator: P.B.T UL 94-V0 rated.
- 1.2 Contact: Brass,t=0.20mm.
- 1.3 Shell: Cold rolled steel,t=0.30mm.

2.Specification:

- 2.1 Current rating: 1 A Max.
- 2.2 Dielectric withstanding voltage: 500 V(ac) for 1 minute.
- 2.3 Contact resistance: 30 mΩ Max.
- 2.4 Insulation resistance: 1000 MΩ Min at DC 500V.
- 2.5 Temperature range: -55°C~+105°C

3.Finishes:

- 3.1 Contacts:Gold flashed 1u",3u",5u",10u",15u",30u".
- 3.2 Shell: Nickel plated.

No.	Name	Q'ty	Material	Remarks & Thickness	Finish
4	Back-shell	1	Cold rolled steel	T=0.30mm	Nickel Plated
3	Front-shell	1	Cold rolled steel	T=0.30mm	Nickel Plated
2	Contact	4	Brass	T=0.20mm	Gold Flashed
1	Housing	1	P.B.T	UL 94-V0	Black/Ivory

PART NO.:		MATERIAL:			
MODEL NO.:		FINSH:			
UNIT: mm	SIZE: A4	COLOR:		PART NAME:	
TOLERANCE UNSPECIFIED		DR: 李霞		USB-B TYPE SOLDER(M)	
x	±0.3	CHK: Kevin		DWG NO: S/A-307	
.xxx	±0.20	APP: Kent		SCALE: 2:1	
ANG.	±0.100	06/05/09		SHEET: 1 of 1	
	±.1			REV: A0	