

REV.	ECN NO	LOCATIONS	DESCRIPTION	DATE	REVISER	APPD

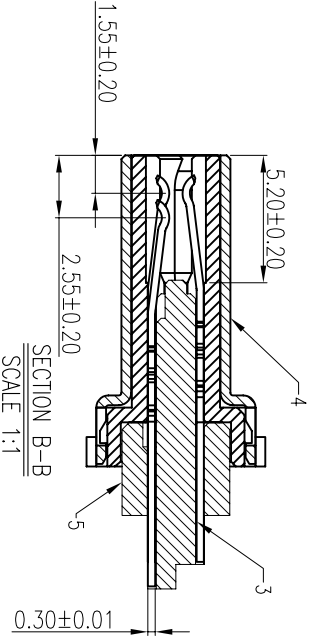
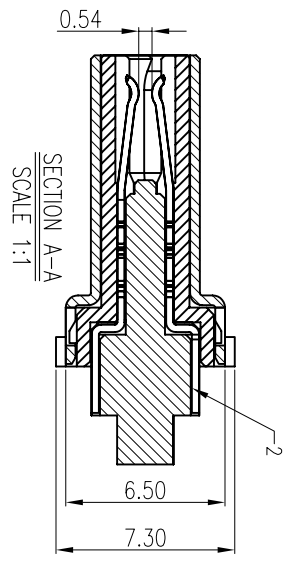
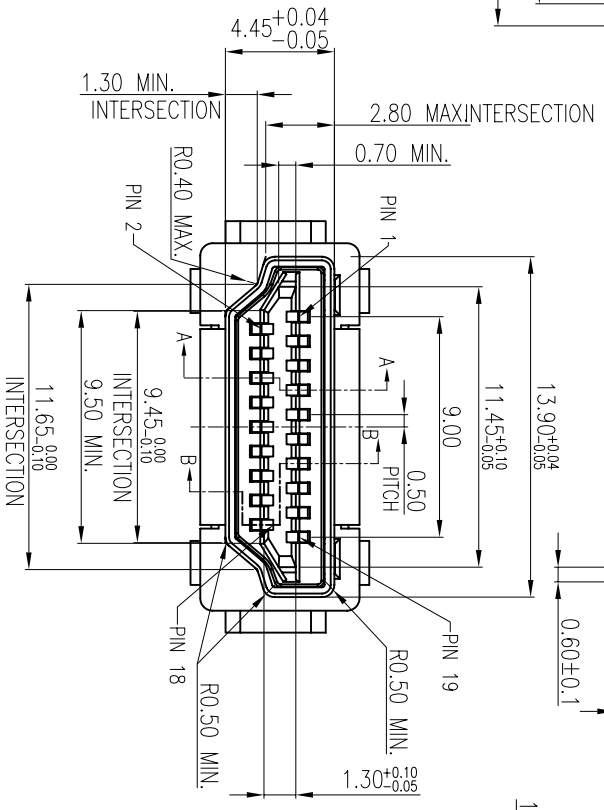
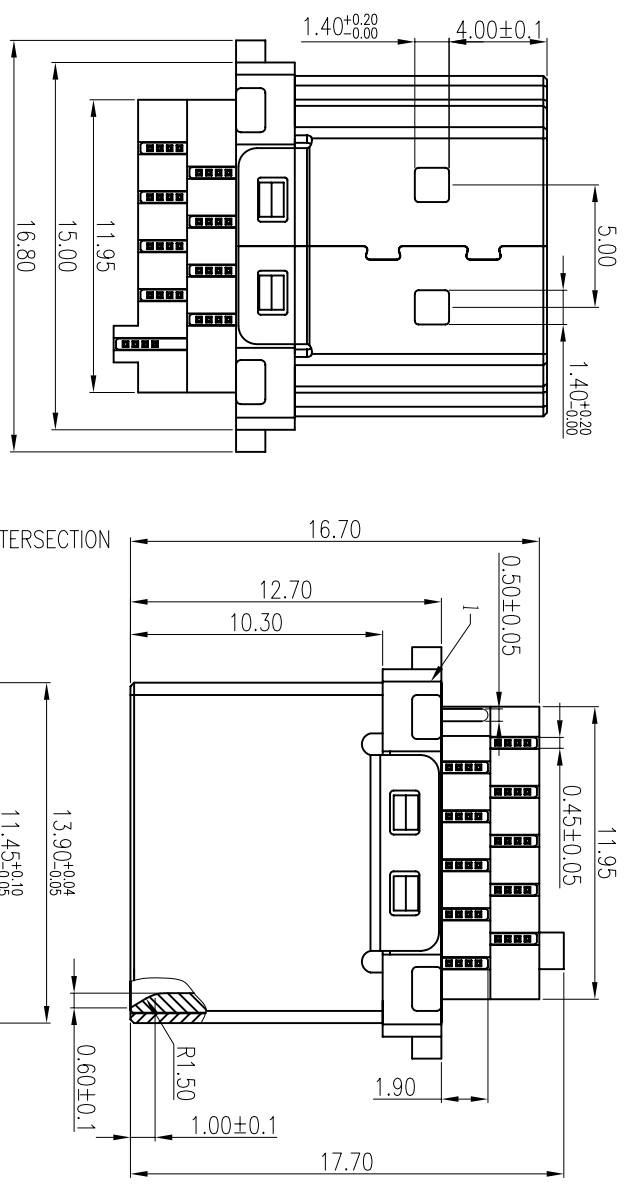

Note:

1. Material:
- 1.1 Insulator: Thermoplastic UL94V-0 color:black.
  - 1.2 Contact: Phosphor bronze T=0.30mm.
  - 1.3 Shell: Brass,t=0.40mm.

2. Specification:

- 2.1 Current rating: 0.5 A Max.
- 2.2 Voltage rating:40V AC(rms) Max.
- 2.3 Contact resistance: 50 milliohms Max.
- 2.4 Dielectric withstanding voltage:100V(ac) for 1 min.
- 2.5 Insulation resistance: 1000 MΩ Min.
- 2.6 Operation temperature range:-25°C~+85°C

PART NO:		MATERIAL:			
MODEL NO:		FINSH:			
UNIT: mm	SIZE:A4	COLOR:		PART NAME:	
TOLERANCE UNSPECIFIED		DR: 吳曉亮 '06/09/06		HDMI-19P 180° SOLDER	
X ±0.3	.xx ±0.20	CHK: Kevin '06/09/06		DWG NO: S/A-379	
.xxx ±0.100	±1	APP: Kent '06/09/06		SCALE: 1:1	
ANG.				SHEET: 1 of 1	
				REV: A0	