

REV.	ECN NO	LOCATIONS	DESCRIPTION	DATE	REVISER	APPD

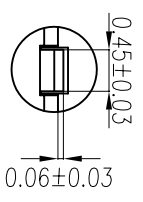
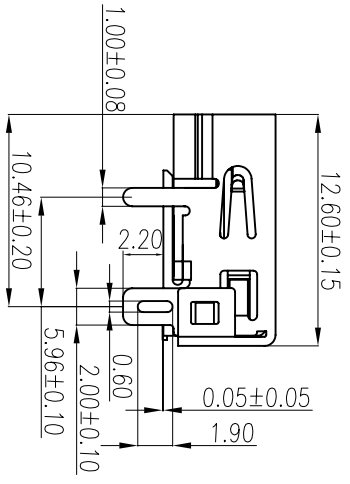
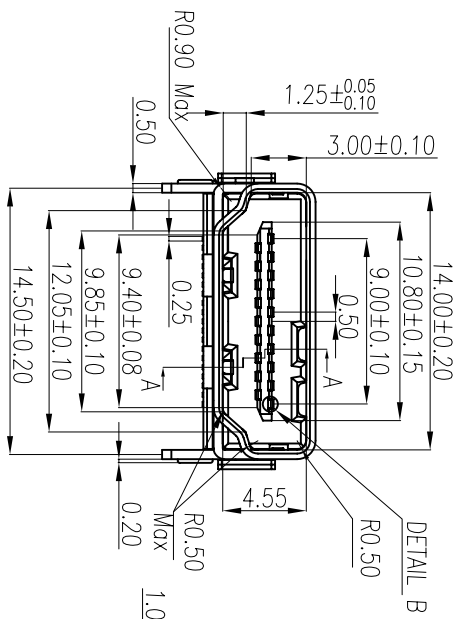
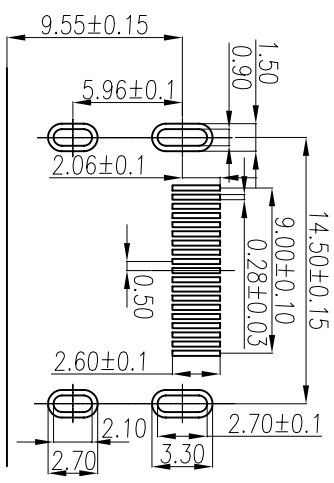
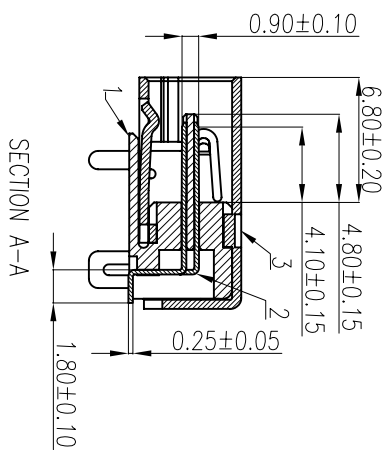
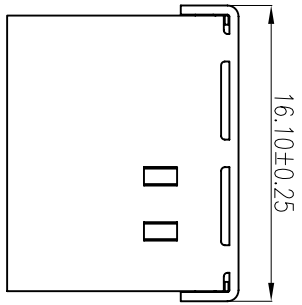

- Note:
- Material:
 - Insulator: LCP UL94V-0 color:back.
 - Contact: Phosphor bronze T=0.25mm.
 - Shell: Brass,t=0.50mm.

- Specification:
 - Current rating: 0.5 A Max.
 - Voltage rating:40V AC(rms) Max.
 - Contact resistance: 30 milliohms Max.
 - Dielectric withstanding voltage:100V(ac) for 1 min.
 - Insulation resistance: 1000 MΩ Min.
 - Operation temperature range:-25°C~+85°C

PART NO:	MATERIAL:	PART NAME:	
MODEL NO:	FINSH:	HDMI-19S SMT 鐵殼帶凸點	
UNIT: mm	SIZE: A4	DWG NO:	S/A-384
TOLERANCE UNSPECIFIED	COLOR:	SCALE: 2.5:1	SHEET: 1 of 2
.x ±0.3	DR: 段林麗 06/03/28	APP: Kent 06/03/28	REV: A0
.xx ±0.20	CHK: KeVin 06/03/28		
.xxx ±0.100			
ANG. ±1°			

HE HSI-CHIN ELECTRONICS CO., LTD

F

E

D

C

B

A

1

2

3

4

5

6

7

F

E

D

C

B

A